

Plate



- ▶ For fastening leveling feet in profiles without a central hole
- ▶ For use as an end connector or T-connector
- ▶ Profile finishing: tapping of thread in the central hole

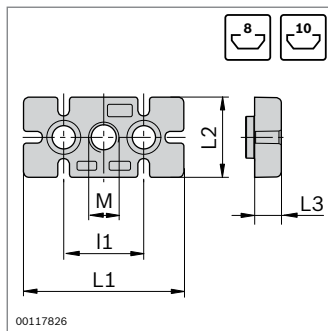

Plate	F (N)	M	L1 (mm)	I1 (mm)	L2 (mm)	L3 (mm)	No.	FS
30x60	8000	M12	60	30	30	11	3 842 536 560	2xFS1
40x80	10000	M12	80	40	40	15	3 842 536 562	2xFS2
45x90	20000	M16	90	45	45	15	3 842 536 564	2xFS2

Material: Plate: Die-cast aluminum
Fastening material: steel; galvanized
Scope of delivery: incl. fastening material (FS)

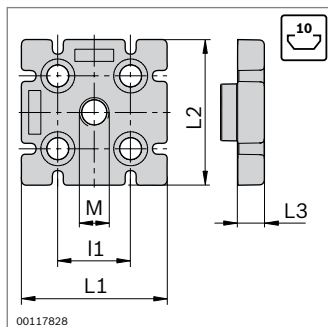
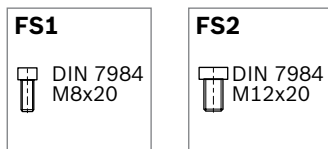

Plate	F (N)	M	L1 (mm)	I1 (mm)	L2 (mm)	L3 (mm)	No.	FS
60x60 8N	10000	M12	60	30	60	11	3 842 536 566	4xFS1
80x80L	10000	M12	80	40	80	15	3 842 529 416	4xFS2
90x90L	20000	M16	90	45	90	15	3 842 511 352	4xFS2
100x100L	20000	M16	100	50	100	15	3 842 529 417	4xFS2

Material: Plate: Die-cast aluminum
Fastening material: steel; galvanized
Scope of delivery: incl. fastening material (FS)

